

sci.electronics.basics: Re: Need help with a circuit

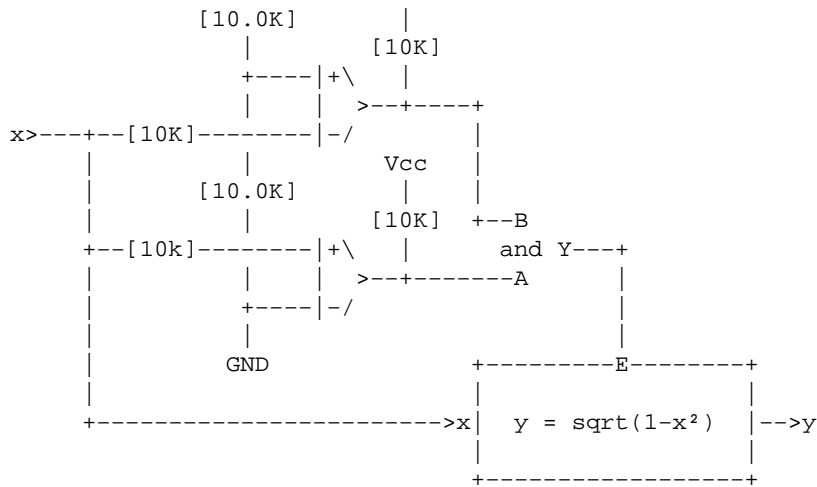

Where the line coming down from the AND would be an enable. When x was less than 0V it would go low, disabling the function machine, then when x was between 0V and 1V it would go high to enable the function machine, and when x rose to higher than 1V it would disable it again for as long as x remained higher than 1V.

--
John Fields