

Re: Driving two transistors with same signal

Source: <http://sci.tech-archive.net/Archive/sci.electronics.basics/2008-05/msg00201.html>

- *From:* "petrus bitbyter" <pieterkraltlaatditweg@xxxxxxxxxxxxxxxxxxxxx>
 - *Date:* Sat, 10 May 2008 14:17:39 +0200
-

"vic" <news@xxxxxxxxxxxxxxxxx> schreef in bericht
[news:48250145\\$0\\$5055\\$426a74cc@xxxxxxxxxxxxxxxxx](mailto:news:48250145$0$5055$426a74cc@xxxxxxxxxxxxxxxxx)

BobW wrote:

"BobW" <nimby_NEEDSPAM@xxxxxxxxxxxxxxxxx> wrote in message
news:B7mdnSJSKb17P77VnZ2dnUVZ_obinZ2d@xxxxxxxxxxxxxxxxx

"vic" <news@xxxxxxxxxxxxxxxxx> wrote in message
[news:48233453\\$0\\$20289\\$426a74cc@xxxxxxxxxxxxxxxxx](mailto:news:48233453$0$20289$426a74cc@xxxxxxxxxxxxxxxxx)

Hi,

I have two common anode 7-segments displays, and only one wire to drive them. I need to achieve the following : when the control signal is +5V, display1 is ON and display2 is OFF. When the signal is 0V, display1 is OFF and display2 is ON. When the signal is not connected (high impedance), both displays are OFF.

I tried using a NPN transistor for display1 and a PNP for display2, connecting their bases together. It works when the driving signal is present, but when the signal is floating current flows from the base of the PNP to the base of the NPN and both transistors turn each other on, resulting in both displays being ON.

The circuit that didn't work :

VCC
+
|

Re: Driving two transistors with same signal

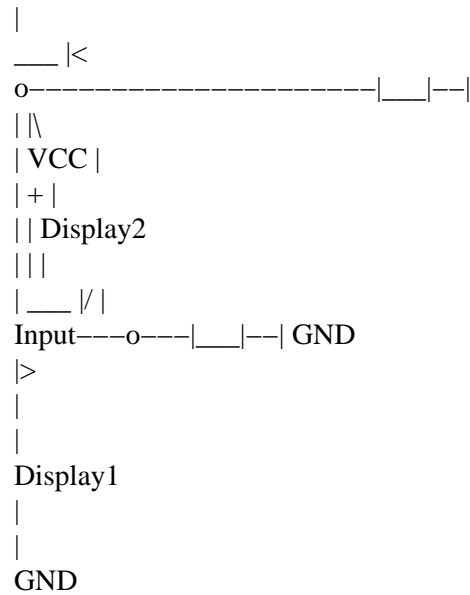

Is there a way to achieve this ?

Thanks.

Try this:

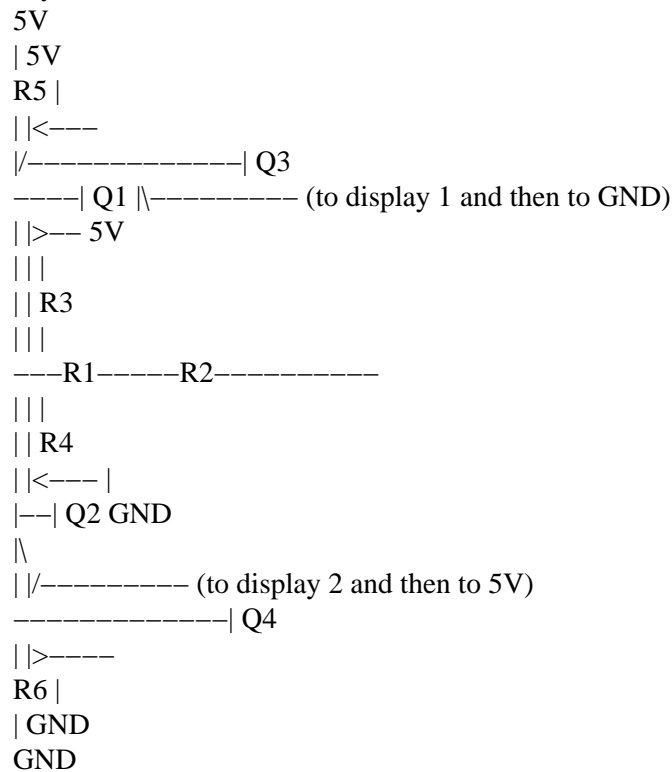

Q1 and Q2 form a comparator so that when the input is floating they will both be off. R3 and R4 set the input threshold.

Re: Driving two transistors with same signal

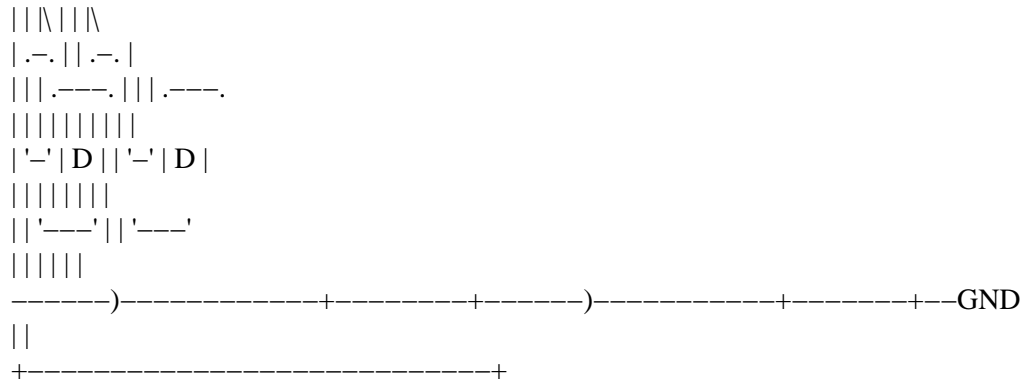

created by Andy's ASCII-Circuit v1.24.140803 Beta www.tech-chat.de

petrus bitbyter